

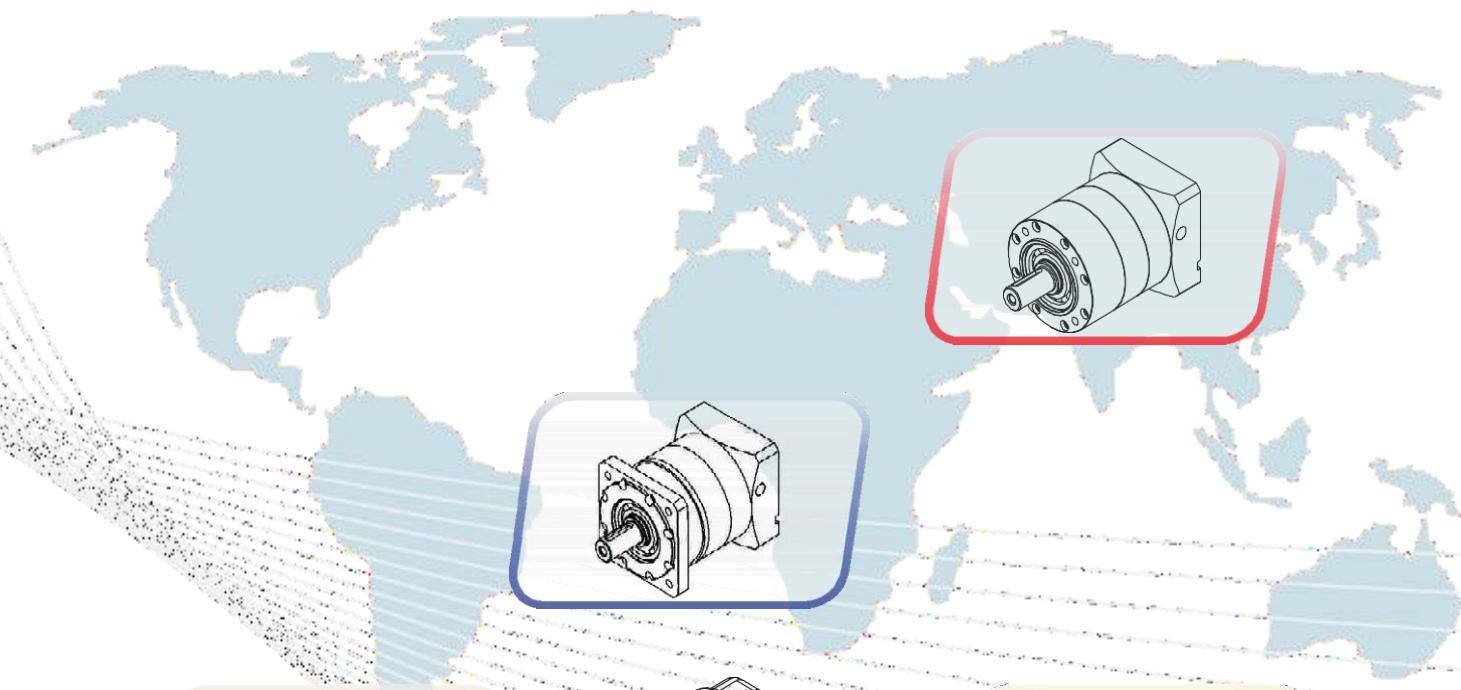

# MACTROL-REFU

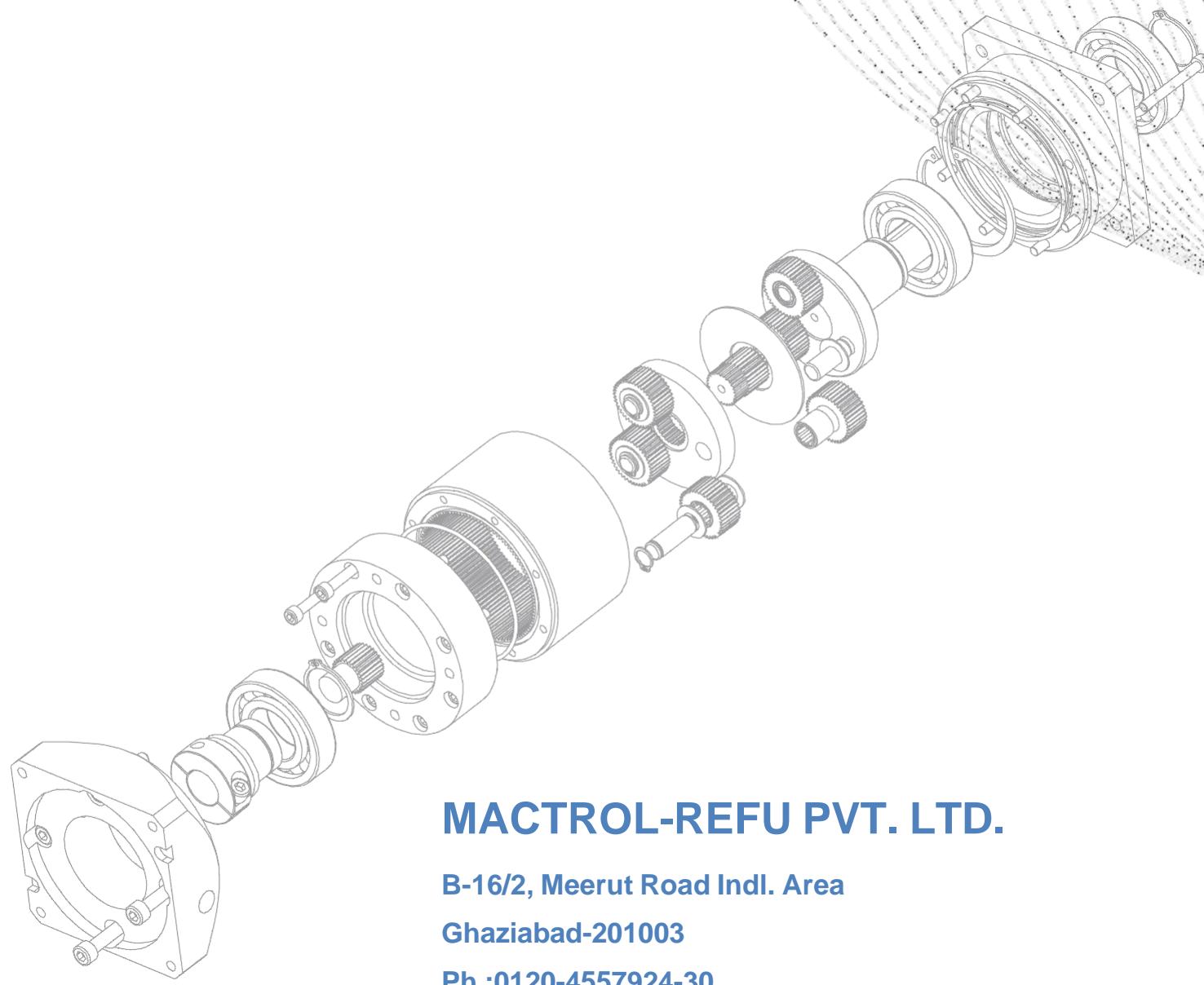

## MACTROL-REFU PVT. LTD.

B-16/2, Meerut Road Indl. Area  
Ghaziabad-201003  
Ph.:0120-4557924-30  
Email :sales@mactrol.org  
URL: www.mactrol.org

## Precise Planet Gear Box

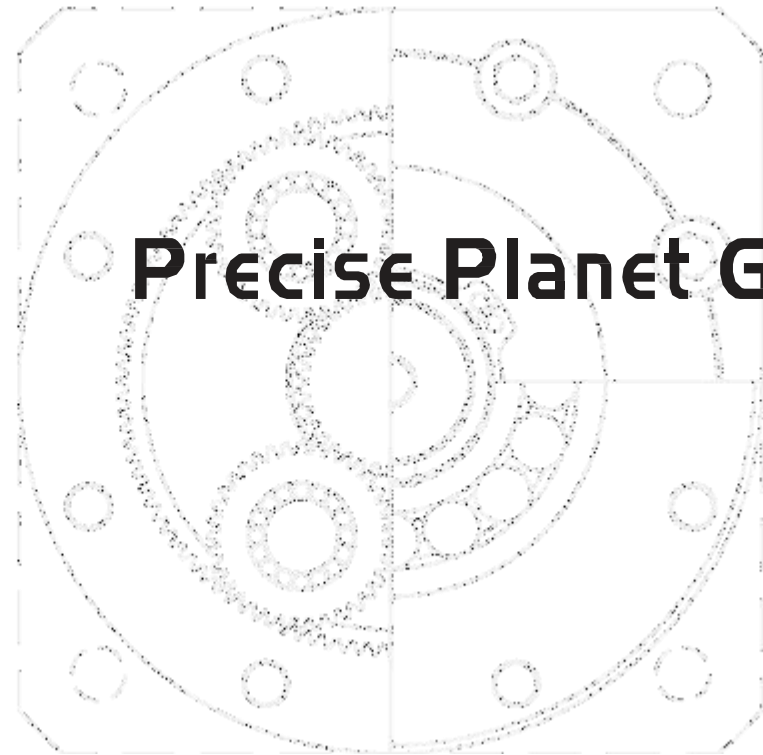
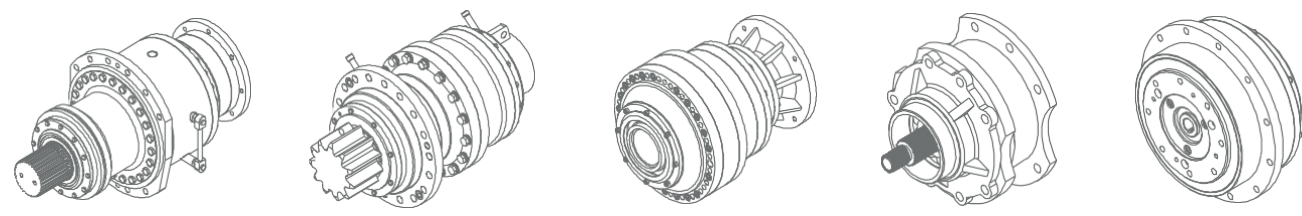

## Reducer type description

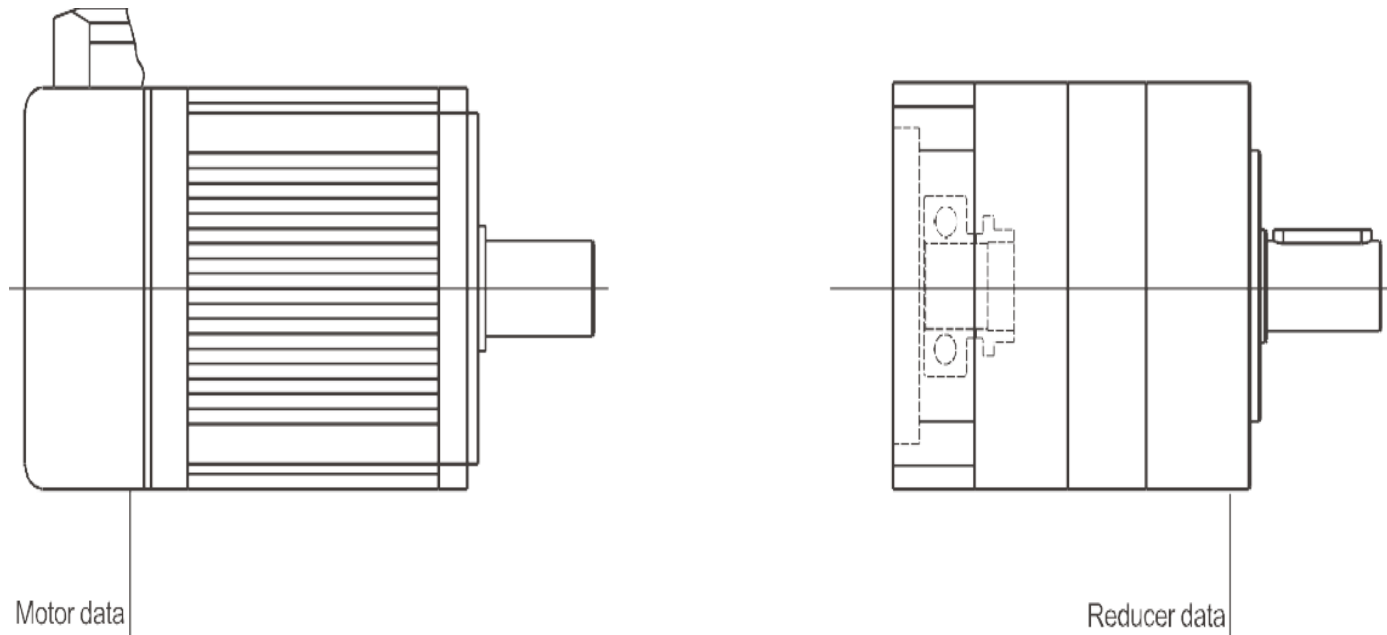

With the speed reducer, the need to provide the motor mounting dimension  $\varnothing S * LR / \varnothing LB * LE / 4 - \varnothing LZ - \varnothing LA$ . To check the rationality of the motor and reducer with performance, the need to provide more detailed parameters (such as the rated speed, rated torque, maximum torque)

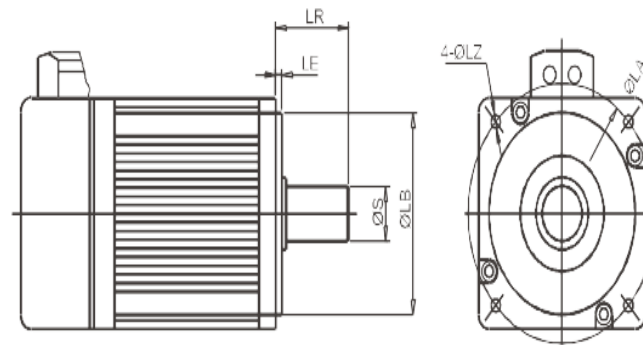

PLE060 - L1 - 5 - S2 - P2 - T / The motor size or drawings.

Reducer specifications According to the selection of products introduction	Stage L1: 1-stage L2: 2-stage L3: 3-stage	Ratio According to the choice of various models reducer technical parameters table	Output shaft <small>S2: Shaft with keyway S1: Optical shaft</small> K: hollow single shaft	Accuracy class P2: standard P1: precision P0: high precision	Special	The motor size
---	--	---	--	---	---------	----------------

# Speed reducer special terminology

**Rated input speed n1[rpm]:** The driving speed reducer, such as reducer and motor connected directly, the speed value is the same as the motor speed. In this book Rated input speed is at an ambient temperature of 20 °C measured under the condition of high temperature environment, reduce speed n1.

**Output speed n2[rpm]:** Output speed according to the following formula through the input speed of N1 and transmission ratio I calculated.

$$n_2 = \frac{n_1}{i}$$

**The ratio of i:** Said gear change three major parameters of a movement of value, namely through the reducer ratio to change the speed, torque and moment of inertia.

**Rated output torque of TN[Nm]:**The deceleration time (the continuous working system) can load torque (no wear), conditions should meet the uniform load, the safety coefficient S=1, the theoretical lifetime is 20000 hours; the value of T2N to comply with ISO DP 6336 and ISO 281 standard gear standard bearings.

**Maximum torque of Tmax[Nm]:** The speed reducer under static conditions or high output torque can afford to stop condition. Usually the peak load or starting load. (Tmax=2 · TN)

**The actual torque of Ts[Nm]:** The actual working conditions required torque depends on the application. The rated torque TN reducer must be greater than the torque.

**Calculated by the torque of Tc[Nm]:** Will be used in the selection of speed reducer, can Ts torque and coefficient of FS required by the actual, according to the following formula

$$T_c = T_s \cdot f_s \leq T_N$$

**Effective rate η:** The ratio of output power to input power. Due to the power loss due to friction makes the efficiency is always less than 1 (100%), the efficiency of labeled samples is reducer at full load movement were measured. The smaller the input power and torque are smaller, efficiency is lower, this is because the idling torque is constant. At this time, the power loss is not improved. Speed will also affect the efficiency of.

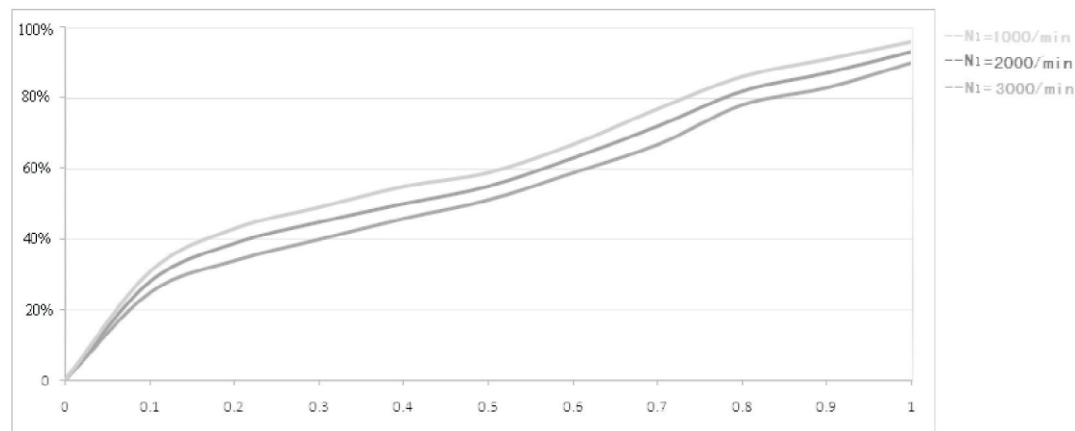

**Hysteresis curve:** Delay detection is to reverse the reducer stiffness. Get the hysteresis curve by testing. When detecting, the reducer input end is fixed, and then in the two rotation direction output were continuously loaded into the T2B maximum acceleration torque, and then gradually unloading, instrument record the moment imitation difference angle, the curve is a closed curve, from which we can calculate the backlash reducer (j) and torsional stiffness (Ct21).

$$C_{t21} = \frac{\Delta T}{\Delta \varphi}$$

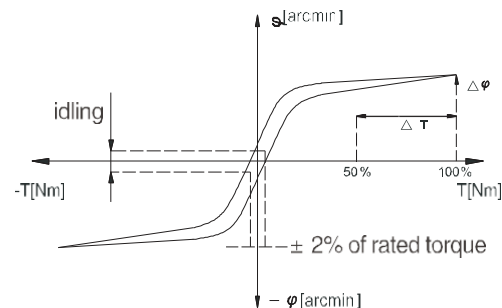

**Return gap JT [Arcmin]:** The maximum deviation of the output shaft of the speed reducer and the input angle. When measuring the gear input end is fixed, and then use the torque meter load certain torque at the output (2%T2B), to overcome the friction force in the speed reducer

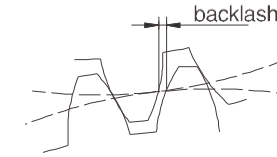

**Arc [Arcmin]:** Once divided into 60 minutes of arc (=60 Arcmin=60). If the return gap standard is 1 Arcmin, meaning that the gear box to a circle, angular deviation of output is 1/60 °. In practical application, the angle deviation and shaft diameter of b=2 π · R · a ° /360 °. That is to say, the output end of radius 500mm, gear accuracy of jt=3', deviation reducer turn to b=0.44mm.

**Moment of inertia J[Kgcm2]:** Represents an object to try to keep their rotational state (or stationary or rotating) a value characteristic. Value refers to the input.

**Inertia ratio λ:** Refers to the load inertia and inertia (motor drive system and the ratio between the speed reducer). This ratio determines the controllability of the system. The lambda value is greater, the moment of inertia is larger difference, high dynamic movement process more difficult to control, suggestions as far as possible the lambda value control in < 5. Reducer can reduce 1/2 load inertia.

**The noise of [dB]:** The selection of low noise reducer complete sets of equipment, contribute to environmental protection and health protection. The speed ratio and speed directly affects the noise level, is generally the higher the speed, more noise; noise ratio is smaller. In the sample value is the input speed is 3000rpm/min, with no load, measured from the reducer by one meter distance.

**The average life of [h]:** The speed reducer under the rated load, the rated input speed work in non continuous time.

**The axial force Fa[N]:** Refers to a force parallel to the axis of the. It is parallel to the output shaft. Action point and its output shaft axial deviation of a (Y2), will form a bending moment extra. The axial force of more than shown in the sample of the rated value, must use the coupling to counteract the bending force. [such as].

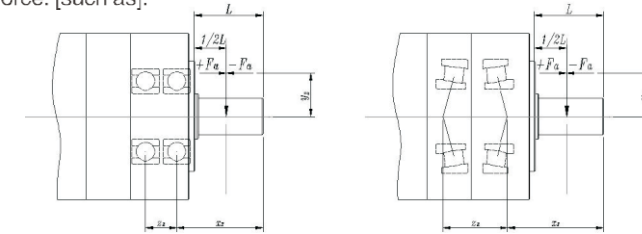

**Radial force of Fr [N]:** The effect of a vertical force on the axial force. Action point it with the shaft end with axial distance of (x2), this point as a leverage point. A bending moment form a lateral force.

**The safety factor S:** The safety coefficient is equal to the ratio of the reducer of the rated power input and power of motor.

**The use of coefficient fs:** Application characteristics using the coefficient of performance of speed reducer, it takes into account the load type and the daily working time of speed reducer. (detailed data type description)

**Clamping hub:** Add the hub for connecting the motor and reducer input end. If the motor shaft diameter is smaller than the inner diameter of the clamping hub, with a shaft sleeve. In order to ensure the high input speed combined with the surface and zero backlash concentricity of the transfer. The mechanism of improvement in our next, in order to achieve the dynamic balance can meet need not check any installation requirements.

**Axle sleeve:** The motor shaft diameter is smaller than the reducer clamping hub, and a sleeve to offset the diameter difference.

In accordance with the standard speed reducer:

Standard working temperature °C	-25 ~ +90
Special working temperature °C	-40 ~ +120
	IP65
	Effective lubrication
	Arbitrarily
	D in 42955-N
	JB 1799-76

# Reducer selection

The selection of reducer should be considered the type of structure, the installation form, bearing working conditions, output speed, etc.

To determine the sample size: the carrying capacity of reducer is in the rated speed, working less than 12 hours per day, every hour starting number less than 10, it is smooth and shock free conditions.

If there is different usage should be selected according to the following steps..

## (一) Check of the selected configuration:

a) according to the type of load, per hour and used to determine the coefficients of FS stop times and expected service life

The coefficient (fs)						
oadtype	Starting times per hour Z	The daily running time (h)				
		h<4	4<h<8	8<h<12	12<h<16	16<h<24
uniform load	Z<10	0.85	0.95	1.00	1.20	1.60
	10<Z<30	0.90	1.10	1.15	1.40	1.80
	30<Z<100	1.00	1.20	1.30	1.60	2.00
Secondary load	Z<10	1.00	1.20	1.30	1.60	2.00
	10<Z<30	1.10	1.35	1.45	1.80	2.20
	30<Z<100	1.20	1.45	1.60	2.00	2.40
heavy load	Z<10	1.20	1.45	1.60	2.00	2.40
	10<Z<30	1.30	1.55	1.75	2.20	2.60
	30<Z<100	1.40	1.65	1.90	2.40	2.80

1. On the basis of the required torque  $T_s$ , calculated the torque according to the following formula:

$$T_c = T_s * f_s$$

2. The transmission ratio of the required output speed  $N_2$  and the input speed  $n_1$ :

$$i = n_1 / n_2$$

3. To determine the  $T_c$  and  $i$ , according to the rated value table, select the most close to the calculation value of transmission ratio and gear units that meet the following conditions:

$$T_N \geq T_c$$

4. The safety factor [S]

Safety coefficient can press the table to choose

	The minimum safety factor ( $S_{min}$ )
High reliability	1.50~1.60
High reliability	1.25~1.30
General reliability	1.00~1.10

## (二) check

After completion of the selection of the reducer, the following method can be used to check:

1. maximum torque

Confirm the instantaneous peak load torque and load rated maximum torque  $T_{max}$  starting torque can not exceed the speed reducer.

The specific values of parameters in the reducer ratings are listed in the table.

2. Cantilever load

Aim at the gear rack, cantilever synchronous belt wheel to bear large radial or axial force, when make a choice, according to a certain speed and force on the shaft extension  $\frac{1}{2}$ , the value of radial or axial force that you need must be less than the standard value of the sample book's (note speed value. The lower the speed, the radial force bearing is high. Stress points farther away from the shoulder, the radial bearing capacity will decline). If special circumstances, and our engineering staff.

3. If need to extend the working life, choose life coefficient ( $f_L$ ) in the following table

working life	5000h	10000h	20000h	25000h	50000h	100000h
$f_L$	0.66	0.81	1.00	1.32	1.62	2.00

4. Radial load

For the role in the load axis point, need to be checked by the following formula:

$$F_r \geq F_{rj} * f_L$$

The  $F_r$  is the rated radial load output shaft center, the  $F_{rj}$  refers to the calculation of the output shaft with radial force

If the cantilever load is not in the axial midpoint, determine whether the offset distance  $X$ , our engineers will according to the specific conditions, the calculation of rated load, for the output speed and the working life is different, need to consider the velocity coefficient:

$n_2$		25	50			500	
$f_{n2}$	2.00	1.51	1.23	1.00	0.88	0.76	0.62

Working life coefficient ( $f_L$ ) in the table, must meet the following conditions:

$$F_r * f_{n2} \geq F_{rj} * f_L$$

5. Thrust load

Count the size and direction of axial load  $F_a$  on an axis. To select the most appropriate according to the speed reducer output type

and axial direction and the adjustment coefficient  $K_a$ . The axial force direction express of (+) and (-), have illustrated glossary.

$$F_a \geq F_{aj} * K_a$$

The  $F_a$  is the rated output shaft axial load, the  $F_{aj}$  refers to the calculation of the output shaft with axial force

Detected by the application of load axial characteristics determine the load factor in the  $K_a$  table:

$K_a$	load characteristic		
	uniform load	Secondary load	heavy load
	1.0	1.25	1.5

If there is the axial force and radial force at the same time, please contact with technical department.

# PLE060 precision planetary reducer

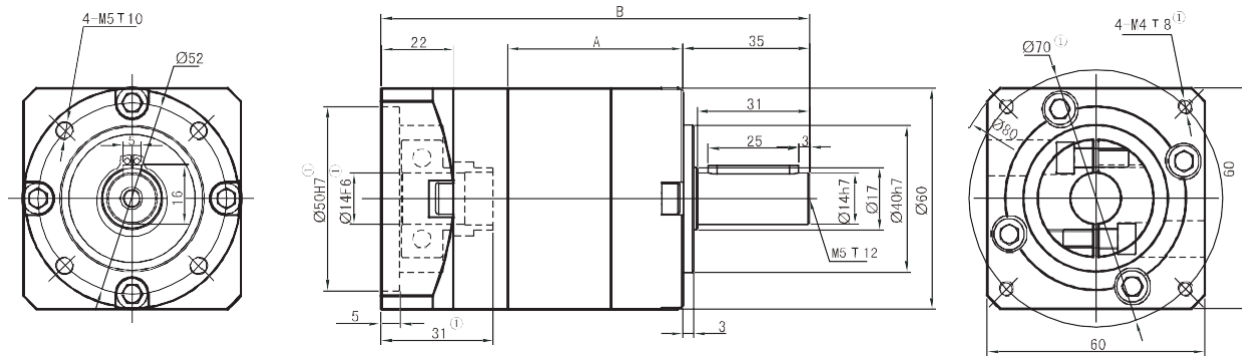

The motor shaft diameter is too small, need to tie in with the shaft sleeve installation, shaft sleeve minimum wall thickness of 1mm

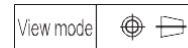
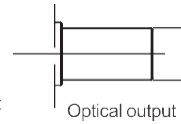

Stage	Stage 1 (Contains the speed ratio 3 4 5 7 10)		Stage 2 (Contains the speed ratio 12 14 20 25 28 35 40 50 70 100)				Stage 3 (Contains the speed ratio 80 100 125 140 175 200 250 300 400 500 700 1000)						
	A	B	A	B	A	B	A	B					
Length(mm)	46.5	118.5	63.0	135.0	79.5	151.5							
	4000		4000				4000						
	8000		8000				8000						
	485		605				670						
	380		490				550						
	About 0.6		About 0.3				About 0.3						
	96		94				90						
	Precision: <3	Standard: <8	Precision: <5	Standard: <10	Precision: <8	Standard: <12							
	≤58		≤58				≤58						
	1.0		1.3				1.6						
	>20000												
	2.3												
	Effective lubrication												
	The input and output to the same												
	IP65												
	arbitrarily												

Installation

	3 <sup>①</sup>	4	5	7	10	12 <sup>②</sup>	16	20	25	28	35	40	50	70
	16.5	27.0	29.5	19.5	8.5	30.0	30.0	30.0	33.0	30.0	33.0	30.0	33.0	21.5
	33.0	54.0	59.0	39.0	17.0	60.0	60.0	60.0	66.0	60.0	66.0	60.0	66.0	43.0
	0.107	0.094	0.092	0.091	0.091	0.107	0.094	0.092	0.092	0.091	0.091	0.091	0.091	0.091

Moment of inertia(Ko<sup>2</sup>m<sup>2</sup>)

	80	100 <sup>①</sup>	100 <sup>②</sup>	125	140	175	200	250	280	350	400	500	700	1000
	37.5	9.5	37.5	41.0	37.5	41.0	37.5	41.0	37.5	41.0	37.5	41.0	27.0	11.5
	75.0	19.0	75.0	82.0	75.0	82.0	75.0	82.0	75.0	82.0	75.0	82.0	54.0	23.0
	0.092	0.091	0.092	0.092	0.091	0.091	0.091	0.091	0.091	0.091	0.091	0.091	0.091	0.091

Subscript 1: Motor is different, matching size will vary, the adapter will be different. Our reducer can be matched to fix with any motor.

Subscript 2: Acting on the output shaft center (1/2 axis strengths), permitted radial force and axial force (be forced at the same time), when the output speed of 1-Stage reducer is 100rpm, or 2-stage's output speed is 50rpm, or 3-stage's output speed is 10rpm.

# PLE090 precision planetary reducer

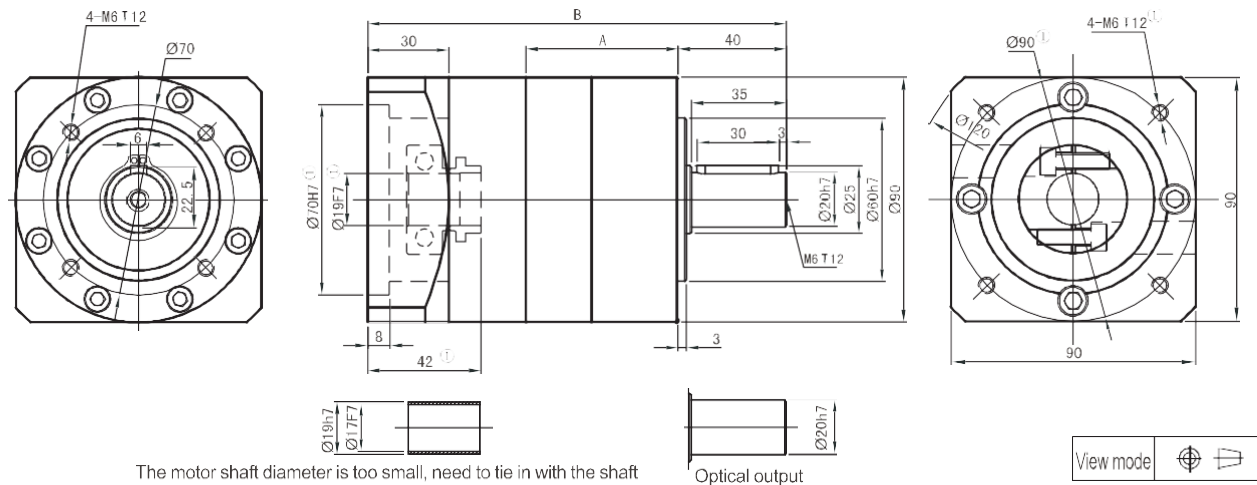

Stage	Stage 1 (Contains the speed ratio 3 4 5 7 10)		Stage 2 (Contains the speed ratio 12 16 20 25 28 35 40 50 70 100)		Stage 3 (Contains the speed ratio 80 100 125 150 200 250 300 400 500 700 1000)	
	A	B	A	B	A	B
Length(mm)	56.0	154.5	80.0	178.5	104.0	202.5
	3500		3500		3500	
	6000		6000		6000	
	1020		1270		1420	
	850		1100		1250	
	About 0.8		About 0.4		About 0.4	
	96		94		90	
	Precision: <3	Standard: <8	Precision: <5	Standard: <10	Precision: <8	Standard: <12
	≤62		≤62		≤62	
	2.8		3.4		4.0	
	>20000					
	7.5					
	Effective lubrication					
	The input and output to the same					
	IP65					
	arbitrarily					

	3 <sup>①</sup>	4	5	7	10	12 <sup>②</sup>	16	20	25	28	35	40	50	70
	60.0	86.0	94.5	64.0	39.5	96.0	96.0	96.0	105.5	96.0	105.5	96.0	105.5	71.5
	120.0	172.0	189.0	128.0	79.0	192.0	192.0	192.0	211.0	192.0	211.0	192.0	211.0	143.0
	0.4	0.309	0.291	0.285	0.283	0.4	0.309	0.291	0.291	0.285	0.285	0.283	0.283	0.283

	80	100 <sup>②</sup>	100 <sup>③</sup>	125	140	175	200	250	280	350	400	500	700	1000
	120.0	44.0	120.0	132.0	120.0	132.0	120.0	132.0	120.0	132.0	44.0	132.0	89.5	55.0
	240.0	88.0	240.0	264.0	240.0	264.0	240.0	264.0	240.0	264.0	88.0	264.0	179.0	110.0
	0.291	0.283	0.291	0.291	0.285	0.285	0.283	0.283	0.283	0.283	0.283	0.283	0.283	0.283

Subscript 1. Motor is different, matching size will vary, the adapter will be different. Our reducer can be matched to fix with any motor.  
 Subscript 2. Acting on the output shaft center (1/2 axis strengths), permitted radial force and axial force (be forced at the same time), when the output speed of 1-Stage reducer is 100rpm, or 2-stage's output speed is 50rpm, or 3-stage's output speed is 10rpm.

# PLE120 precision planetary reducer

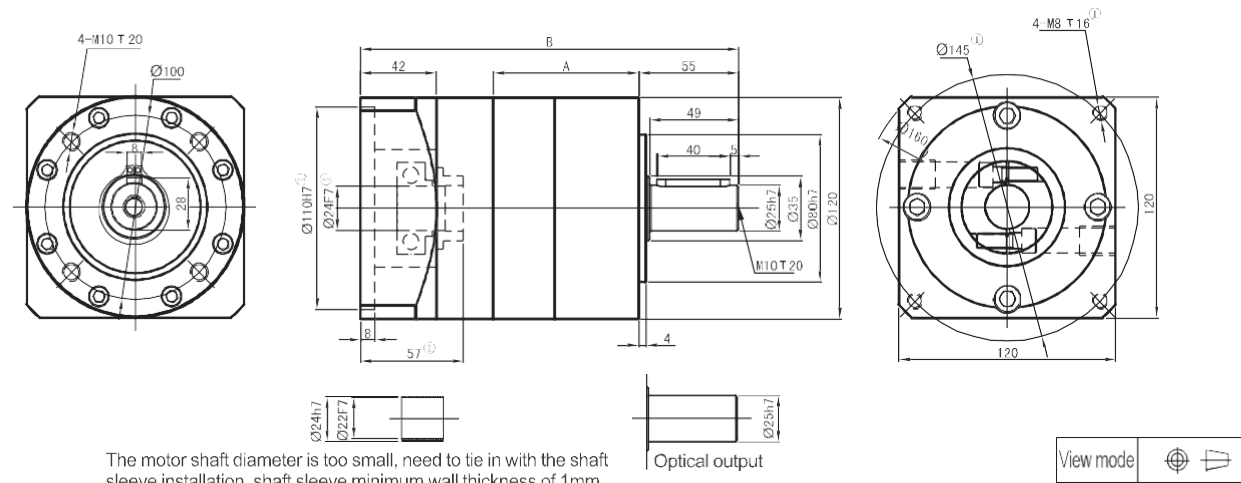

Stage	Stage 1 (Contains the speed ratio 3 4 5 7 10)		Stage 2 (Contains the speed ratio 12 16 20 25 28 35 50 70 100)		Stage 3 (Contains the speed ratio 80 100 125 140 175 200 250 300 400 500 700 1000)	
	A	B	A	B	A	B
Length(mm)	80.5	209.0	112.0	240.5	143.5	272.0
	3000		3000		3000	
	4800		4800		4800	
	2230		2840		3020	
	1550		2100		2600	
	About 1.3		About 0.6		About 0.6	
	96		94		90	
	Precision: <3	Standard: <8	Precision: <5	Standard: <10	Precision: <8	Standard: <12
	≤65		≤65		≤65	
	6.8		8.8		11.0	
	>20000					
	15.0					
	Effective lubrication					
	The input and output to the same					
	IP65					
	arbitrarily					

Installation

	3 <sup>(1)</sup>	4	5	7	10	12 <sup>(2)</sup>	16	20	25	28	35	40	50	70
	148.0	222.0	235.0	158.0	93.0	250.0	250.0	250.0	264.0	250.0	264.0	250.0	264.0	177.0
	296.0	444.0	470.0	316.0	186.0	500.0	500.0	500.0	528.0	500.0	528.0	500.0	528.0	354.0
	1.65	1.22	1.15	1.13	1.11	1.65	1.22	1.15	1.15	1.13	1.13	1.11	1.11	1.11

Moment of inertia(Kgcm<sup>2</sup>)

	80	100 <sup>(2)</sup>	100 <sup>(1)</sup>	125	140	175	200	250	280	350	400	500	700	1000
	310.0	104.0	310.0	329.0	310.0	329.0	310.0	329.0	310.0	329.0	310.0	329.0	220.0	130.0
	620.0	208.0	620.0	658.0	620.0	658.0	620.0	658.0	620.0	658.0	620.0	658.0	440.0	260.0
	1.15	1.11	1.15	1.15	1.13	1.13	1.11	1.11	1.11	1.11	1.11	1.11	1.11	1.11

Subscript 1. Motor is different, matching size will vary, the adapter will be different. Our reducer can be matched to fix with any motor.

Subscript 2. Acting on the output shaft center (1/2 axis strengths), permitted radial force and axial force (be forced at the same time), when the output speed of 1-Stage reducer is 100rpm, or 2-stage's output speed is 50rpm, or 3-stage's output speed is 10rpm.

# PLE160 precision planetary reducer

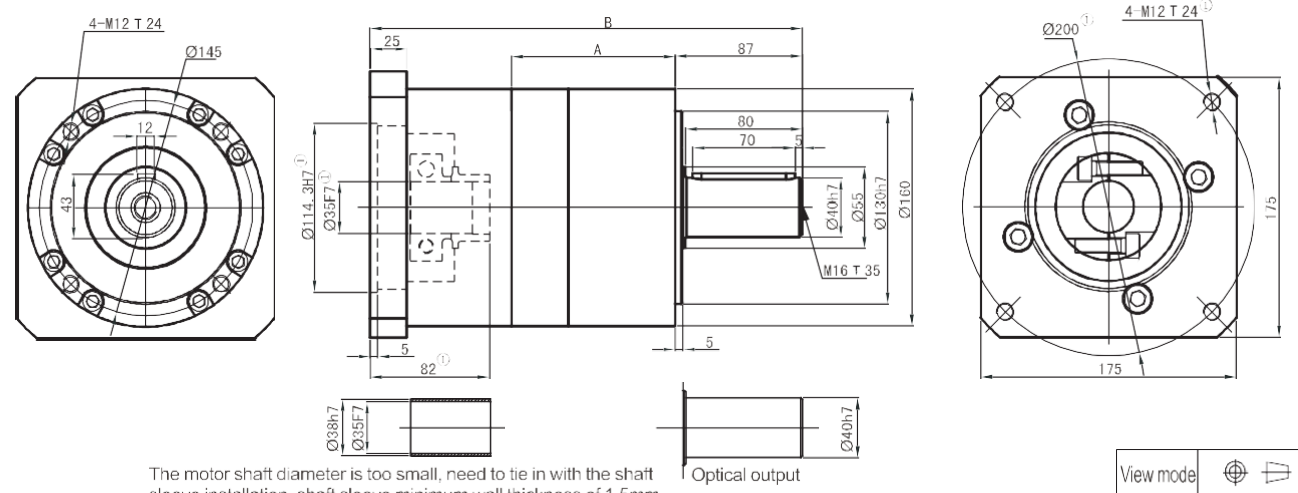

K 向

Stage	Stage 1 (Contains the speed ratio 3 4 5 8)		Stage 2 (Contains the speed ratio 9 12 16 20 25 32 40 64)		Stage 3 (Contains the speed ratio 60 80 100 120 160 200 256 320 512)	
	A	BB	AA	B	A	B
Length(mm)	112.0	296.0	151.0	335.0	190.0	374.0
Rated input speed(rpm)	3000		3000		3000	
Maximum input speed(rpm)	4500		4500		4500	
The maximum radial force(N) <sup>(2)</sup>	2200		2700		4650	
The maximum axial force(N) <sup>(2)</sup>	2300		3000		6200	
No load torque(Nm)	About 3.2		About 2.1		About 2.1	
Efficiency with full load(%)	96		94		90	
Back lash(arcmin)	Precision: <3	Standard: <8	Precision: <5	Standard: <10	Precision: <8	Standard: <12
Noise(dB)	≤68		≤68		≤68	
Weight(Kg)	19.0		25.0		31.0	
Average lifetime(h)	>20000					
Torsional rigidity(Nm/arcmin)	27.0					
lubricant	Effective lubrication					
direction of rotation	The input and output to the same					
Protection level	IP65					
Installation	arbitrarily					

	3	4	5	8	12	16	20	25	32	40	60	64	80	100
	310.0	605.0	420.0	270.0	680.0	680.0	680.0	460.0	680.0	460.0	900.0	310.0	900.0	900.0
	620.0	1210.0	840.0	540.0	1360.0	136.0	1360.0	920.0	1360.0	920.0	1800.0	620.0	1800.0	1800.0
	6.31	5.15	4.93	4.84	6.31	5.15	4.93	4.93	4.84	4.84	9.31	4.84	4.93	4.93

	120	160	200	256	320	512								
	580.0	900.0	580.0	900.0	580.0	400.0								
	1160.0	1800.0	1160.0	1800.0	1160.0	800.0								
	4.84	4.84	4.84	4.84	4.84	4.84								

Subscript 1. Motor is different, matching size will vary, the adapter will be different. Our reducer can be matched to fix with any motor.  
 Subscript 2. Acting on the output shaft center (1/2 axis strengths), permitted radial force and axial force (be forced at the same time), when the output speed of 1-stage reducer is 100rpm, or 2-stage's output speed is 50rpm, or 3-stage's output speed is 10rpm.



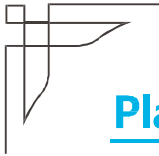

**Plan and notes**

**PLAN&MEMO**

Date: \_\_\_\_\_

Place: \_\_\_\_\_

Member: \_\_\_\_\_

**SUBJECT**

---

---

---

---

---

---

---

---

---

---

---

---

---

---

---

---

---

---

---

---

---

---

---

---

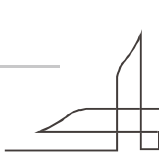
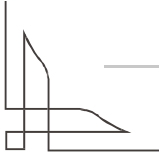

**MACTROL-REFU PVT. LTD.**

**B-16/2, Meerut Road Indl. Area**

**Ghaziabad-201003**

**Ph.:0120-4557924-30**

**Email :sales@mactrol.org**